



Liquid Level Gauges 6500 Series

Application

The COLM (COntec Level Measurement) 6500 Series Senior™ gauges are designed for use in low pressure tanks 0–25 psig [0–1.7 Bar] containing diesel fuel, gasoline, fuel oil and lubricating oils.

Typical applications are on generators, boats, construction equipment, farm equipment and home heating.



General Specifications

- Accuracy:** Direct dials ±3%; TwinSite™ ±7%
- Temperature Range:** -40 °C to +70 °C
- Shock & Vibration:** Suitable for mobile applications.
- Power:** 0.5 watts maximum (TwinSite™)
- Tank Pressure:** Up to 0–25 psig [0–1.7 Bar]
- Approvals:**
 - ATEX approved
 - UL listed for flammable liquids (optional)

Materials of Construction

- Head:** Die cast aluminum
- Stem & float arm:** Tempered aluminum
- Gears & Bearings:** Stainless steel
- Drive Magnet:** Alnico
- Gear Housing:** Acetal plastic
- Float:** Nitrile rubber
- Gasket:** Buna-N, 0015-00004 or 0015-00079
- Direct Reading Dial:** Aluminum with acrylic crystal
- Side Reading Dial:** Aluminum with polycarbonate crystal
- TwinSite™ Sender:** Polyamide
- Screws:** Zinc-plated steel 1/4" -28X 9/16" long

Technical data

Modell	Action	Mounting	Dial, Sender or Switch Data
6540	Gear	Top	Senior™ TwinSite™ (0–30, 0–90, or 240–30 Ohm ranges)
6543		C/L or Angel	
L6543	Lever	C/L	
6560	Gear	Top	Senior™ side-reading fractional
6580		C/L or Angel	Senior™ direct-reading fractional
6583		C/L	
L6583	Lever	C/L	

Twinsite Dial

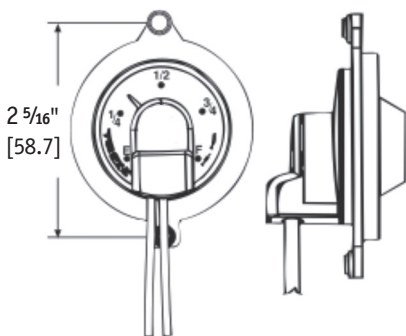

Side-Reading Dial

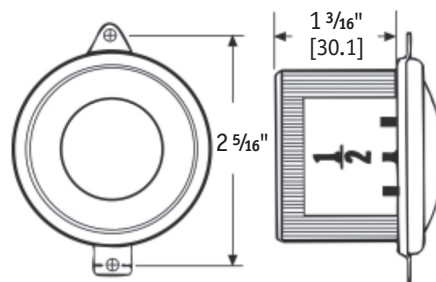

Direct-Reading Dial

